

Duratumf[®] KIWI SHEDS

Quality - Built In

ASSEMBLY INSTRUCTIONS



MK3B

BASE SIZE 3380mm x 3380mm

ASSEMBLY INSTRUCTIONS

Tools Required:

- Drill
- Drill Bit 3.5mm
- Drill Bit 6mm (for clear roof panel only)
- Hex Drive 5/16
- Riveter (free Duratuf riveter supplied in kit)
- Hammer
- Nail Punch
- Tape Measure
- Ladder or Saw stool
- Spanners x 2
- String Line
- Tin Snips
- Skillsaw and Jigsaw (for floor only)
- Masonry Drill and 10mm Masonry Bit (for Bolt Down Kit only)

Before you start:

- **Read all instructions carefully.**
- Identify all parts and check quantities against checklist.
- If you are making your own floor refer to Raised Base Plate section now.

Safety:

- Do not attempt to build your shed in high winds.
- Beware of sharp edges.
- Protect your eyes and ears.
- Use electric tools with care. Use a Safety Trip Switch.
- It is easier and quicker if this shed is erected by two people.

Select your site:

- Your shed must be level. Achieve this by either levelling the ground or by using blocks.
- If your shed is to be positioned on wet or damp ground, we recommend that your shed is raised up off the ground slightly.

ROOF COLOUR WALL COLOUR INVOICE NO: BASE SIZE:

QTY	LENGTH	DESCRIPTION	PACKED	CHECKED
			<input type="checkbox"/>	<input type="checkbox"/>
			<input type="checkbox"/>	<input type="checkbox"/>
8	2.280m	Gable End Wall Sheets	<input type="checkbox"/>	<input type="checkbox"/>
6	1.890m	Wall Sheets	<input type="checkbox"/>	<input type="checkbox"/>
2		Door - Standard <input type="checkbox"/> Security <input type="checkbox"/>	<input type="checkbox"/>	<input type="checkbox"/>
1		Instruction Booklet	<input type="checkbox"/>	<input type="checkbox"/>
2	0.260m	Jack Studs - 140 x 45mm	<input type="checkbox"/>	<input type="checkbox"/>
4	0.200m	Jack Studs - 60 x 45mm	<input type="checkbox"/>	<input type="checkbox"/>
1		Hardware Pack	<input type="checkbox"/>	<input type="checkbox"/>
		Touch-up Paint & Brush	<input type="checkbox"/>	<input type="checkbox"/>
1		Duratuf Riveter	<input type="checkbox"/>	<input type="checkbox"/>
4	3.700m	Roof Sheets	<input type="checkbox"/>	<input type="checkbox"/>
			<input type="checkbox"/>	<input type="checkbox"/>
			<input type="checkbox"/>	<input type="checkbox"/>
			<input type="checkbox"/>	<input type="checkbox"/>
			<input type="checkbox"/>	<input type="checkbox"/>

OPTIONAL EXTRAS

QTY	LENGTH	DESCRIPTION	PACKED	CHECKED
			<input type="checkbox"/>	<input type="checkbox"/>
			<input type="checkbox"/>	<input type="checkbox"/>
WINDOWS				
		Fixed Window Frame	<input type="checkbox"/>	<input type="checkbox"/>
	0.580m	Glaze Beads	<input type="checkbox"/>	<input type="checkbox"/>
	0.603 x 0.603m	Glass	<input type="checkbox"/>	<input type="checkbox"/>
			<input type="checkbox"/>	<input type="checkbox"/>
		Louvre Window Frame	<input type="checkbox"/>	<input type="checkbox"/>
	0.588 x 0.150m	Glass	<input type="checkbox"/>	<input type="checkbox"/>
1		Window Hardware Pack	<input type="checkbox"/>	<input type="checkbox"/>
			<input type="checkbox"/>	<input type="checkbox"/>
CLEAR ROOF PANEL				
	3.700m	Roof Sheets	<input type="checkbox"/>	<input type="checkbox"/>
	1.850m	Flat Roof Sheet	<input type="checkbox"/>	<input type="checkbox"/>
	1.850m	Clear Roof Panel	<input type="checkbox"/>	<input type="checkbox"/>
	1.175m	Ridge Flashing	<input type="checkbox"/>	<input type="checkbox"/>
1		Clear Roof Hardware Pack	<input type="checkbox"/>	<input type="checkbox"/>
			<input type="checkbox"/>	<input type="checkbox"/>
SECURITY PARTS				
		Security Double Door Hardware Pack	<input type="checkbox"/>	<input type="checkbox"/>
		Alarm - MA20	<input type="checkbox"/>	<input type="checkbox"/>
		Shed light	<input type="checkbox"/>	<input type="checkbox"/>
		Bolt Down Kit	<input type="checkbox"/>	<input type="checkbox"/>
		Peg Down Kit	<input type="checkbox"/>	<input type="checkbox"/>

DATE: / /

PACKED BY:

CHECKED BY:

Total Weight

kg

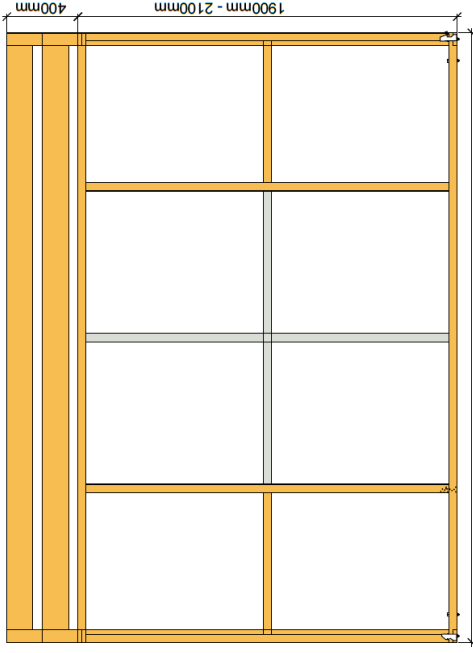
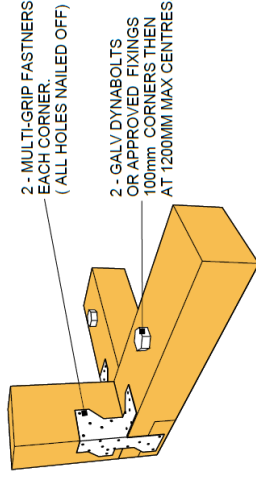

FRONT ELEVATION

CLADDING AND NAILING AS PER THE "ASSEMBLY INSTRUCTIONS".

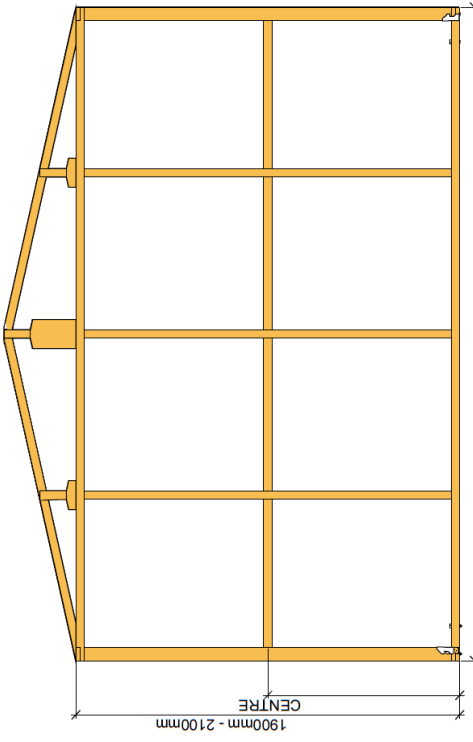

END ELEVATION

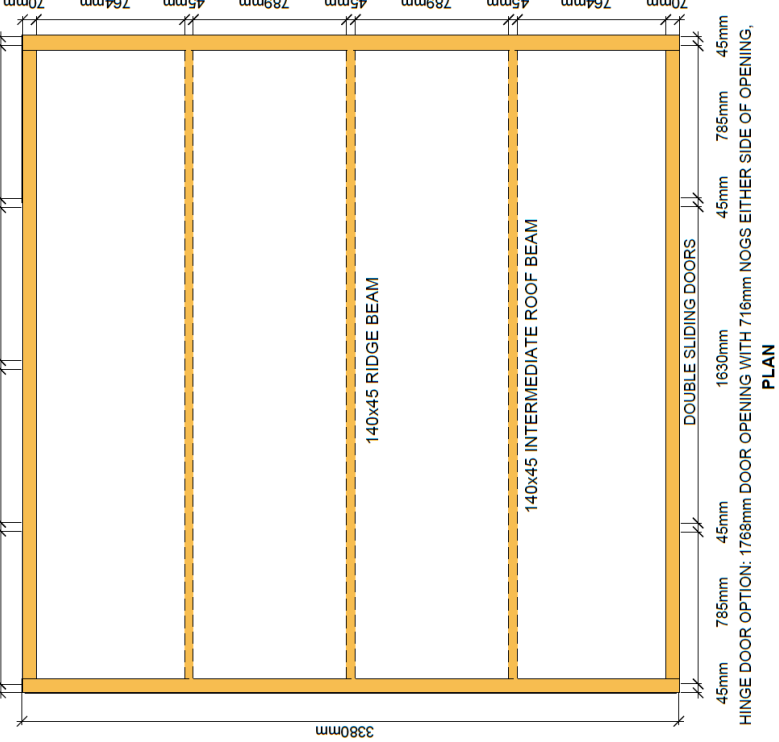

PLAN

- A BOTTOM SIDE PLATES - 2
- B BOTTOM FRONT / REAR PLATES - 2
- C TOP SIDE PLATES - 2
- D TOP FRONT / REAR PLATES - 2
- E STUDS - 15
- F RIDGE BEAM - 1
- G NOGS - 14
- H JACK STUDS - 6
- J INTERMEDIATE ROOF BEAMS - 2
- K ROOF NOGS - 8

RECOMMENDATION FOR THE INSTALLATION OF A CONCRETE OR TIMBER FLOOR: USE THE REQUIREMENTS AS SET OUT IN NZS3604

WHERE THE FLOOR IS TIMBER FRAMED, SECURE STUDS AT EACH CORNER TO A CORNER ANCHOR PILE WITH A 6 KN CONNECTOR

TIMBER FRAMING: GENERALLY TO NZS 3604 STANDARDS
 NOTE: SHEDS CAN BE SITED IN LOCATIONS UP TO AND INCLUDING VERY HIGH (VH) WIND ZONES, AS PER NZS3604:2011, TABLE 5.4

CONSTRUCTION DETAILS
 MK38 KIWI GARDEN SHED
 (3380 X 3380 - 11.42M2)

DRAFTED BY: STEPHEN MCCURDY II | DATE: 20/08/2018

THIS DRAWING IS PROTECTED BY COPYRIGHT. ALL INFORMATION REMAINS THE EXCLUSIVE PROPERTY OF: RIVERLEA GROUP LTD

REVISIONS	
NO	REMARKS
1	
2	
3	
4	
5	

MK3B TIMBER FRAME

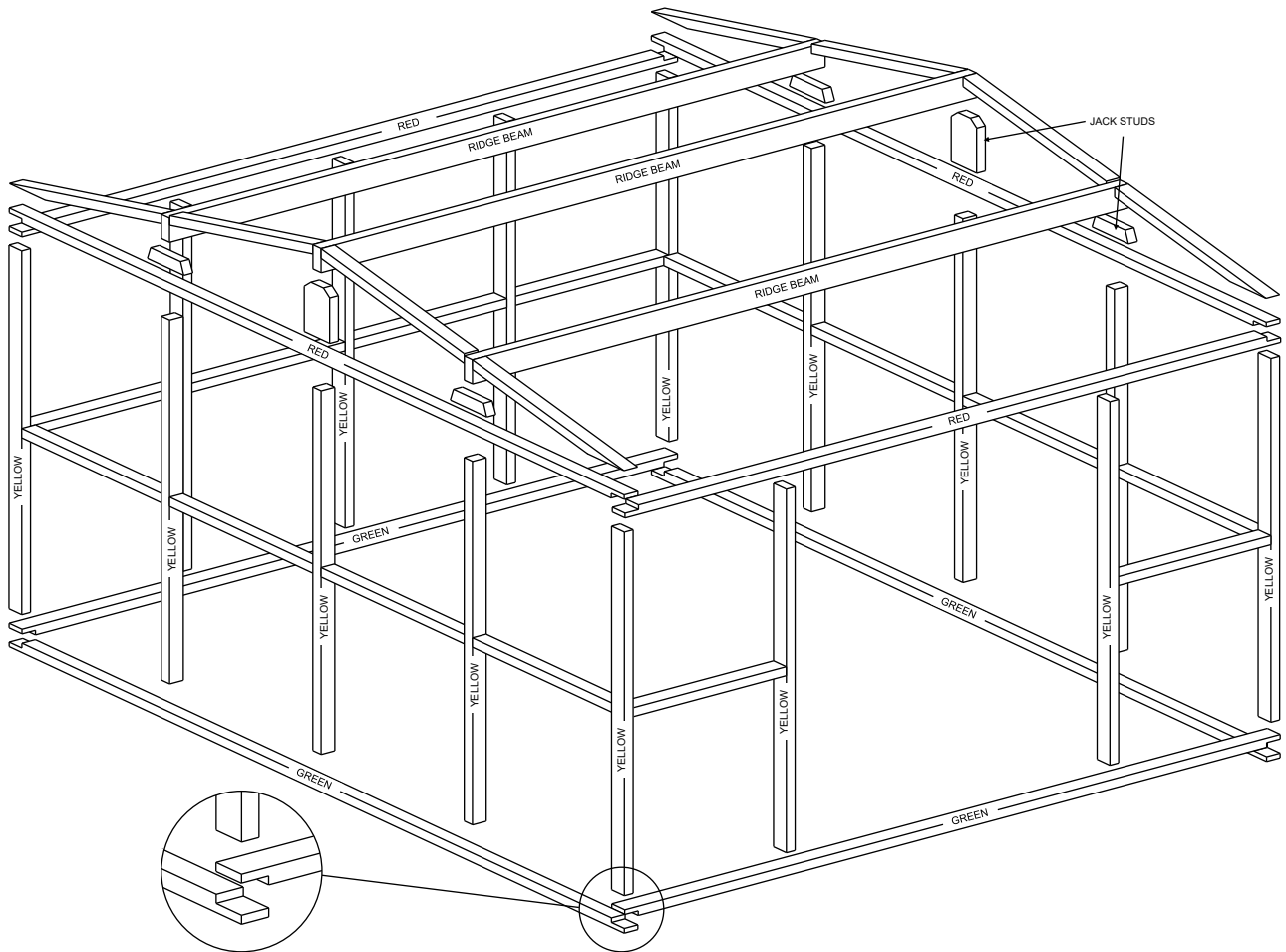

Note: For sheds with the Raised Floor Modification option the studs will be 1.780m long to allow the Wall Sheets to protrude 20mm below the Bottom Plate. Refer to Raised Floor Modification section (Page 15).

Step 1: Back Wall: Select one 3.380m Base Plate (Green), one 3.380m Top Plate (Red) and five Studs (Yellow). Lay out Plates and two Studs on a flat surface and nail together using two 75mm nails per joint. Nail in remaining centre studs using Nogs to get correct position. Position Nogs centrally between Top and Bottom Plates and nail in place. (All Plates, Studs and Nogs are joined together with two 75mm nails each end).

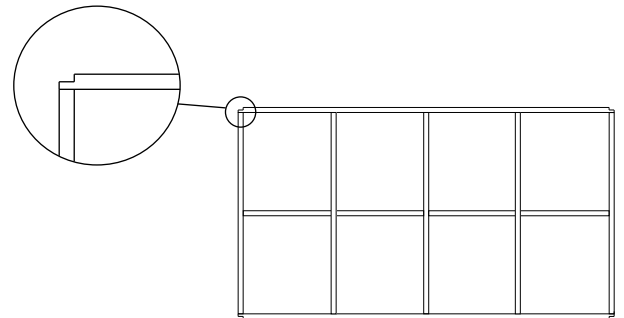

Step 2: Front Wall: Select one 3.380m Base Plate (Green), one 3.380m Top Plate (Red), four Studs (Yellow) and two .785m Nogs. Nail studs to each end of Plates. Nail in remaining two studs using .785m Nogs to get correct position. Position Nogs centrally between Plates and nail in place.

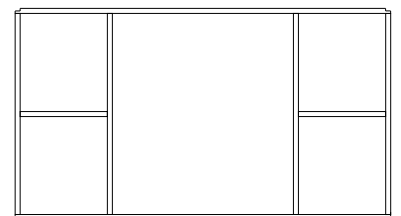

Step 3: End Wall: Select one 3.380m Base Plate (Green), one 3.380m Top Plate (Red), three Studs (Yellow) and two .789m Nogs. Lay out Plates and one Stud on a flat surface and nail Stud centrally between Plates. Nail remaining Studs to Plates using .789m Nogs to get the correct position. Position Nogs centrally between Plates and nail in place. Repeat with second End Frame.

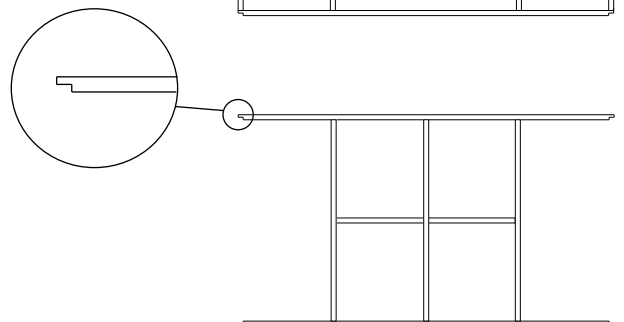

MK3B TIMBER FRAME

Step 4: Stand up Back Wall frame and one End frame and nail together, using two 75mm nails per joint, top and bottom. Stand remaining Frames up and nail together. Nail in remaining .764m Nogs in End Walls.

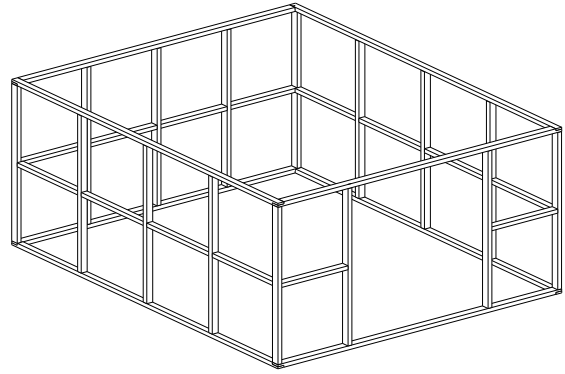

Step 5: Position middle Jack Stud, centrally on End Wall Top Plates and nail in place. Nail remaining Jack Studs in. Position middle Ridge Beam to Jack Stud and skew-nail in place using two 75mm nails each end. Pre-drilling holes before nailing will prevent timber from splitting.

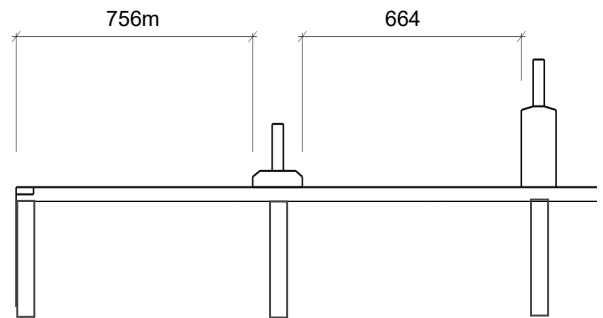

Step 6: Place intermediate Roof Beams by using Roofing Nogs to determine correct position (see *fig. 2*). Nail intermediate Roof Beams in place. Nail 70 x 45mm Roofing Nogs in place (End Wall).

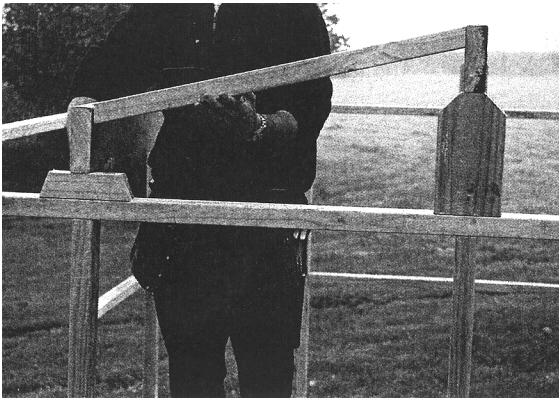
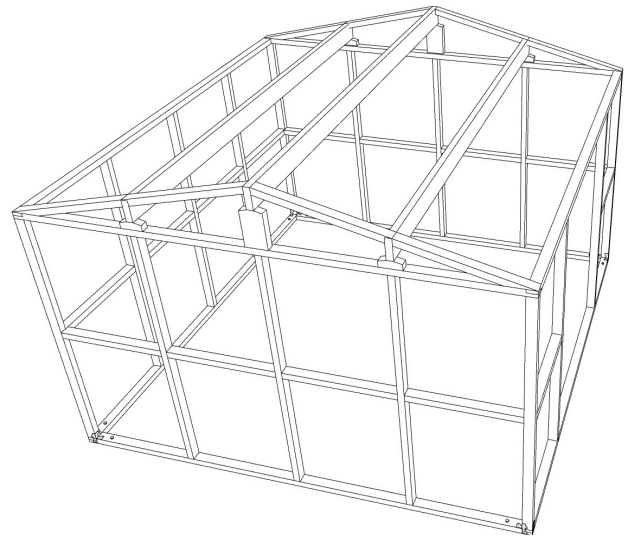
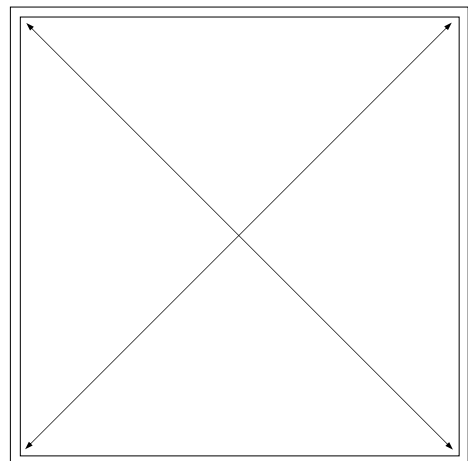

fig. 2.



Step 7: Place Frame in correct position, checking the shed is square and level. Dynabolt Frame to concrete base as instructed on page 4.

Step 8: Nail multigrip brackets to each of the four bottom corners (two per corner). Use 30mm Clouts supplied.



MK3B WALL CLADDING

TO AVIOD CORROSION:

- Where at all possible try not to trap metal filings between two sheets. Remove all metal filings before riveting.
- Carbon in pencils reacts with the Zinc/Aluminium coating on steel. Use ink to mark steel.

TERMS EXPLANATION

- **To Tack:** To Tack on a wall sheet means to use minimum nails hammered partly in to hold Wall Sheets in position. Should a Wall Sheet need to be re-positioned, the nails can easily be prized out.
- If a window is required, identify Wall Sheet(s) with window hole pre-cut. Lean up Wall Sheets where window(s) are to be located.

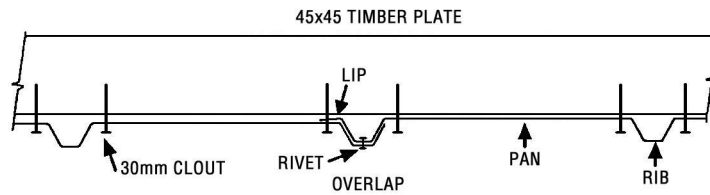
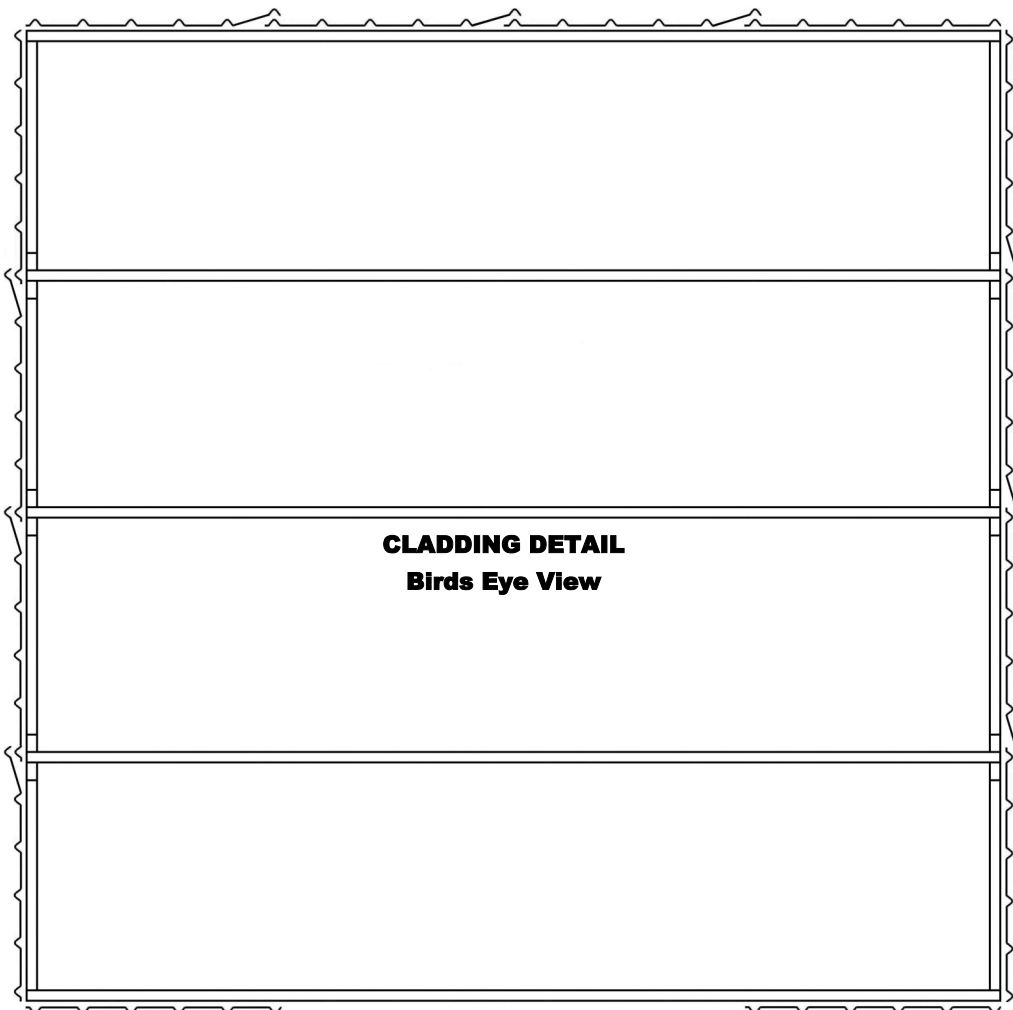

fig. 1



Note:

When fitting Gable End Sheets ensure they overlap correctly (**fig 1**).

The overlap direction may differ from cladding detail.

MK3B WALL CLADDING

Step 1: Front Wall: Start at the left hand side. Position the Wall Sheet with the LIP on the left hand side. Ensuring the LIP is flush with side of the Stud and the top of the Top Plate, tack in place. Repeat with Wall Sheet on the right hand side of doorway.



Step 2: Back Wall: Position the first Wall Sheet with the LIP on the right hand side. Ensuring the LIP is flush with the side of the Stud and the top of the Wall Sheet is flush with the top of the Top Plate, tack in place. Position the next Wall Sheet with the LIP on the right hand side. Overlap as shown in *fig.1* (page 7). Ensuring Wall Sheet is flush with top of Top Plate, tack in place. Repeat with remaining two sheets.



Step 3: End Walls: Lean Gable Wall Sheets against the shed to form gable shape. With the LIP flush with side of Stud tack in place ensuring the bottom of the Wall Sheet is 10mm above the bottom of the Bottom Plate. Tack on remaining Wall Sheets. Repeat with other gable end. If fitting a window, nail in Window Studs and Nog now. Refer to Window instructions.



Step 4: Nailing Off: Nail one 30mm Clout each side of the Rib (two per Pan) into the Top Plates and Bottom Plates. Nail Wall Sheets to mid wall Nogs (one per pan). Nail each corner Wall Sheet to Studs using two 30mm Clouts evenly spaced.

Gable Ends: When nailing Gable Wall Sheets to the Top Plate, use a String Line. At the top of the gable nail one 30mm Clout each side of the Rib (two per Pan) into the Roof Nogs.

MK3B LOUVRE WINDOW (Optional)

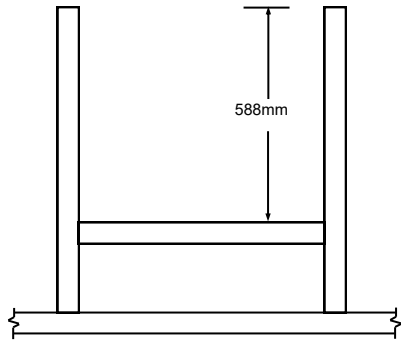

Step 1: Lay out the two window studs (883mm) and Nog (634mm) on a flat surface. Position Nog and nail in place using 2x 75mm nails at each end.



Step 2: On the inside of the shed, position studs and Nog centrally on window opening. Make sure the studs are parallel and nail into Top Plate and end wall Nog.

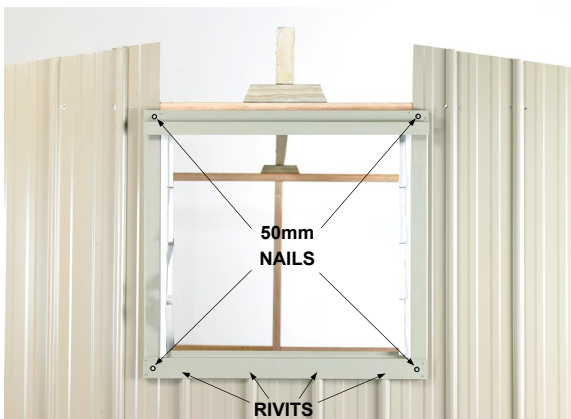

Step 3: Nail wall Sheets to window framing using 30mm clouts. (return to step 4 on page 7 and complete). Then fit Window Frame). Position Window Frame centrally on window opening and rivet it to ribs. Pre-drill holes in each corner and nail Window Frame to framing, using 50mm nails.



Step 4: If the Window is in the gable end, temporarily position the Over Panel above Window Frame. Following the same angle as the gable, mark and cut to suit.



Step 5: Rivet Over Panel to the Window Frame with rivets.



Step 6: From the inside of the shed, slide Louvre Glass into Louvre Units attached to the Window Frame. Bend up tabs to keep Glass in position.

MK3B FIXED WINDOW (Optional)

Step 1: Lay out the two window studs (883mm) and Nog (590mm) on a flat surface. Position Nog and nail in place using two 75mm nails at each end.

Follow Steps 2 - 5 on page 8.

Step 6: From the outside of the shed, place glass in Window Frame. Attach a Glazing Bead (G100) with three rivets to each side of the Window Frame to hold glass in place. Pre-drilling Glazing Beads is recommended.

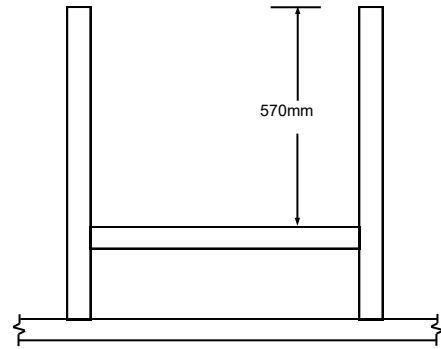

MK3B DOOR JAMB & CORNER FLASHINGS

Step 1: Fit Door Jamb Flashing (A104) in between Top and Bottom Plates and hard against Stud. Attach Door Jamb Flashing with three rivets into Rib on the outside and three 30mm clouts into studs on the inside. Repeat with the other Door Jamb.



Step 2: Measure and cut Doorstep Flashing (A106) to fit in between Door Jamb. Position the Doorstep Flashing in between the Door Jamb at bottom of doorway, nail through top of flashing using five 30mm Clouts. Repeat with the Overdoor Flashing (A105).



Step 3: Fit Corner Flashing (101) over corner Ribs with the top flush with the top of the Top Plate. Rivet in place with six rivets, three each side. Repeat with other three Corner Flashings. When fitting Corner Flashings on front wall, ensure they are parallel with Door Jamb.



MK3B DOORS

Step 1: Position Right-hand Door Track (107) on the front wall with the top of the track 7mm below the top of the timber frame. The right-hand end should be flush with outside edge of right-hand corner flashing.

Pre-drill a hole in the centre of the track and screw in place using one 45mm door track screw. Remove ALL drill filings

Note: *Ensure Door Track screws are screwed in horizontal and screwed hard into flashing. Protruding screw heads can cause door rollers to bind on the screw heads.*

Step 2: Hang right hand door in Door Track. At the right hand end of Door Track, adjust up or down so that the Door hangs parallel with shed. Fit one rivet at right hand end to hold in place. Repeat with left hand end of track.

Note: *Only use rivets at each end of track.*

Step 3: Position left hand Door Track (107). Follow Steps 1 and 2 to hang left hand Door. Where Door Tracks meet in the centre, adjust up and down so that the Doors fit snugly together, then rivet in place.

Step 4: Remove Doors. Pre-drill and screw another 2 screws between the centre screw and the rivets at each end of tracks(5 screws per track). Screw tracks using 45mm door track screws.

Step 5: Clean out ALL drill filings. Also make sure the Wheels are cleaned of drill filings. Re-hang Doors.

Fit outer door stops. Predrill a hole 45mm in from outside edge of Corner Flashing and screw outer door stops in using one Roofing screw per stop. Check doors do not protrude past outside edge of shed.

Fit inner door stops. Predrill a hole 45mm each side of centre and screw inner door stops in using one Roofing screw per stop.

Note– adjust centre door stops left and right to ensure doors close correctly.

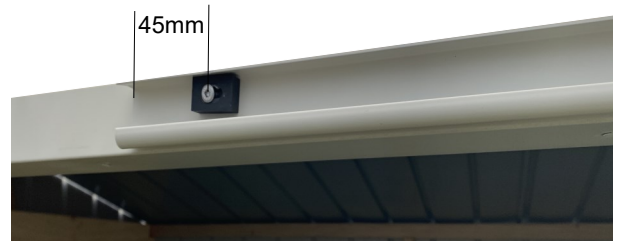

MK3B DOORS

Step 5: Bottom Door Guide: Slide the Door to the corner of the shed. Place the Door Guide (108) over the Guide Brackets on the door and align the end of the Door Guide, flush with outside of the right-hand corner flashing.

Step 6: Lift the door guide up approximately 3mm so that the Door will Slide freely. Pre-drill a hole through the door guide and the end rib of the cladding and screw in place using a 45mm screw.

Step 7: Slide the door to the centre, ensuring that it slides freely. Pre-drill and insert a screw in the other end of the Door Guide. Check that the Door is not binding in the middle then pre-drill and fix with 3 more screws, one in the centre of the guide and the other 2 evenly spaced between (5 screws per guide) into the door step flashing and rib.

Note: For sheds with Raised Base Plate option the Door Step Flashing will protrude down past the Bottom Plate. Attach Door Guide with rivets.

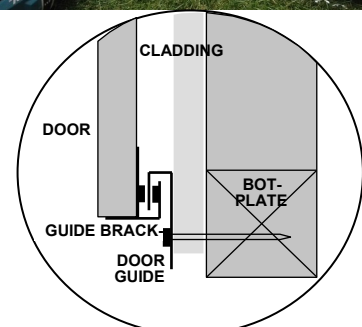

MK3B ROOF

Note: Condensation can form on the under side of shed roof. If building paper is required, fit now. Building paper will need to be supported by netting or roofing twine.

Step 1: Position first Roof Sheet centrally over Ridge Beam on the right hand end of shed with the LIP on the left hand side. (For sheds with a Clear Roof Panel, go to the next page). Position the next Roof Sheet. Ensure it overlaps correctly then rivet together, one rivet in the centre and one 600mm and 1200mm down from the centre on both sides. Fit remaining Roof Sheet.



Step 2: Starting from the left hand end, centralize Roof on Ridge Beam. Ensure Roof is tight against end Wall Sheets, predrill then nail one 50mm Clout through Rib into the Ridge Beam. At the back, line up Ribs on the Roof Sheet with the Ribs on Wall Sheet. Using one 50mm Clout, nail through Rib into Back Top Plate. Repeat at the front.

Note The 10 x 50mm Clouts on end ribs are covered by the Barge Flashings.

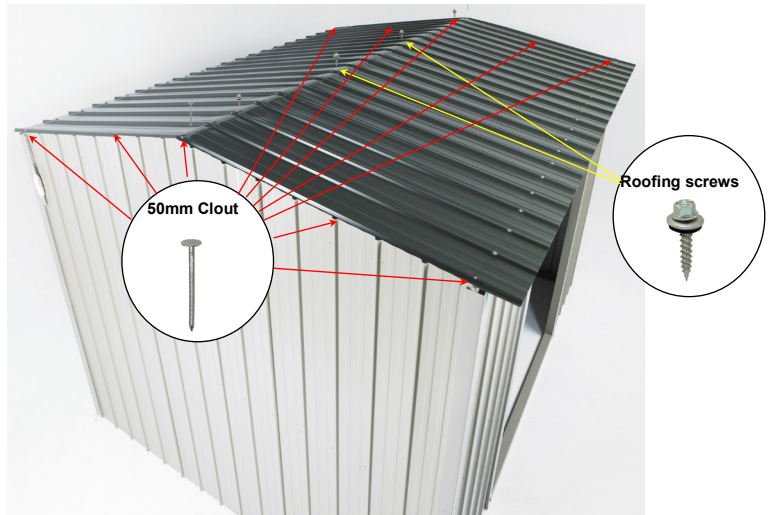

Step 3: Centralize Roof at the other end and nail through Rib into the Ridge Beam and Top Plates, using 50mm Clouts. Ensure Ridge Beams are straight, then Screw one 50mm Roofing Screw into Ridge Beam through each Rib on overlap (one screw per sheet per beam). At the back, set up a String Line in centre of Top Plate. Ensure Top Plate is straight and screw, using one 50mm Roofing Screw per Rib. Repeat at the front.



MK3B CLEAR ROOF PANEL (Optional)

Step 1: Leave a gap where the Clear Panel is to be fitted. Position the next Roof Sheet. Ensure it overlaps correctly, then rivet together, one rivet in the centre and one approximately 600 mm down from the centre on both sides. Fit remaining Roof Sheets, overlapping and riveting as you go. Nail on first Roof Sheet (refer step 3 on page 11).

Step 2: Position clear roof and flat roof sheet (or second clear panel). The flat roof sheet underlaps one sheet and overlaps the other. The clear roof panel **overlaps** both roof sheets. Ensure sheet joins are flush at the outside edge then rivet flat sheets to pressed sheets. Two rivets per join. Centralise roof at the other end and screw in place.

Step 3: Ensure ridge beam is straight, then nail the clear panel and flat roof sheet (or second clear panel) to ridge beam using one 30mm clout per pan. Position on ridge beam and screw in place using six 50mm roofing screws. Screw one 50mm roofing screw into ridge beam through each rib on overlap, (one screw per sheet). Mould the soft edge on the flashing down into the pans of the roof sheet to prevent roof leaks.

Step 4: Continue to fasten roof sheets as per step 4 on previous page (pg11)

Note: When screwing through the clear panel, pre-drill a 6mm hole.

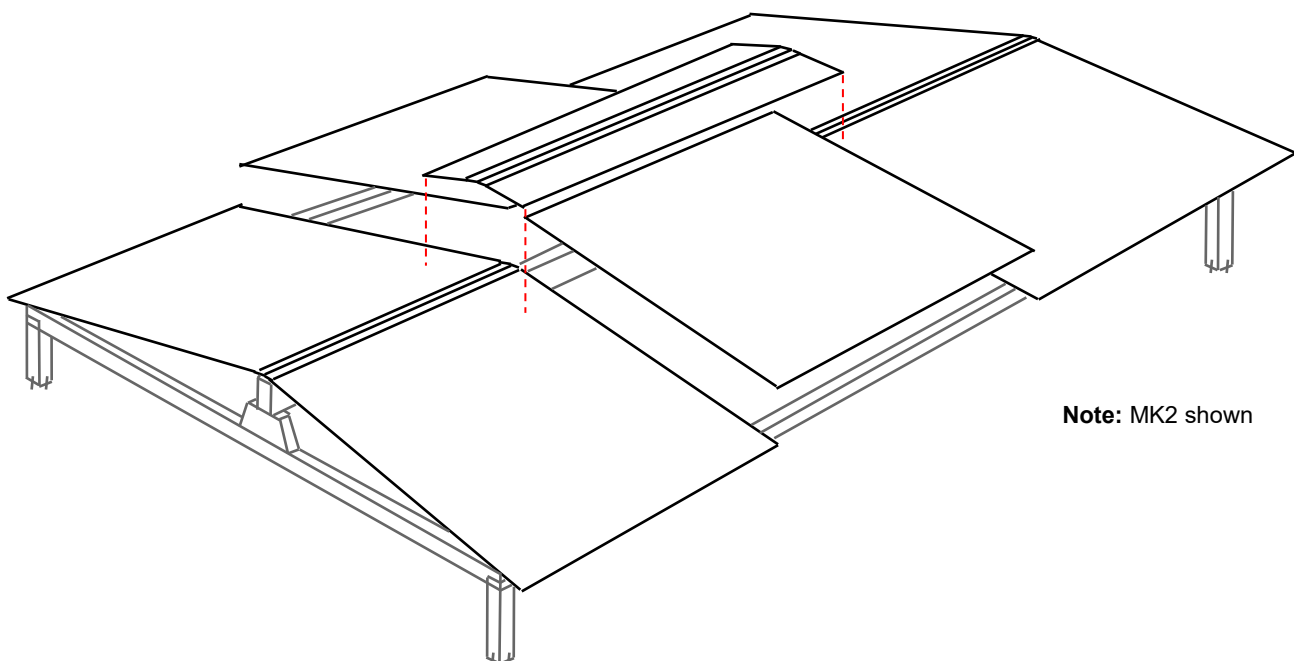
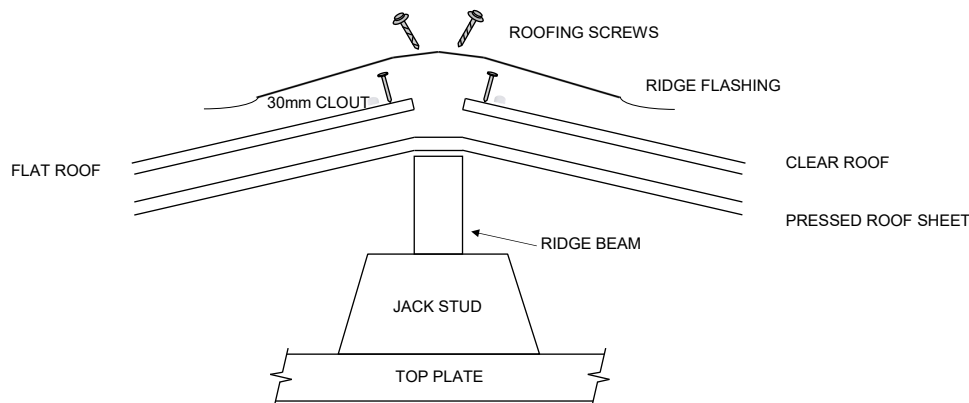

Note: MK2 shown

MK3B BARGE & SPOUTING



Step 1: Attach left hand and right hand barges (C102 & D102) together with three rivets at top overlap. Position Barge Flashings on gable ends. Position Spouting (C103) on the shed and rivet to barge Flashing at each end. Repeat with other Spouting.



Step 2: Centralise Barge Flashing on gable end and rivet in place, one rivet into every second Rib. Fit two rivets through top of Barge into Rib. Repeat with other Barge Flashing. Check Spoutings are straight, then rivet to Roof one rivet every second Rib.

MK3B HASP & STAPLE



Using seven rivets, attach hasp to Left Hand Door and the staple to the Right Hand Door as shown.

RAISED FLOOR MODIFICATION

For sheds being placed on a purpose built floor, (concrete, cobbles, ply etc.), the Wall Sheets will protrude 20mm below the Base Plate. This will stop water flowing in between the Base Plate and Floor.

The Floor should be made 15mm smaller than Base Size.

Note: Although it is not essential, fitting Damp Proof Course in between the Base Plate and the Floor will give added protection against moisture.

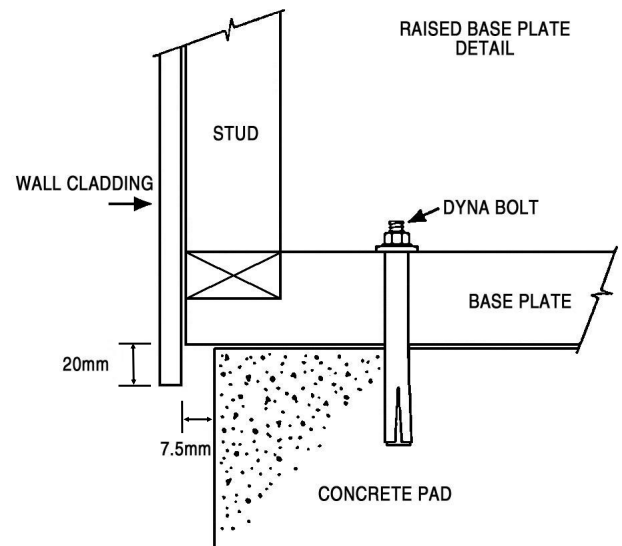

CLEAN UP

- Remove all swarf (drill filings) with a soft brush or rag.
- Hose down roof and walls thoroughly.
- For Coloursteel sheds use touch-up paint provided on all nail heads, rivets and exposed cuts.



DURATUF PREMIUM SHED WARRANTY

GUARANTEE TO CUSTOMER

Congratulations on purchasing a Duratuf Storage Shed. With proper care and attention, this product will last many years. For your benefit **PLEASE READ THE FOLLOWING INFORMATION CAREFULLY.**

WARRANTY ON METAL CLADDING

Riverlea Group Ltd guarantee that the metal roofing and wall cladding on Kiwi and Fortress Garden Sheds may be used in moderate and inland corrosion zones or areas where the first year mild steel corrosion rate is less than 200g/m², and that in these conditions, they will not perforate due to corrosion within 30 years of date of manufacture.

TERMS AND CONDITIONS

1. Damage or corrosion due to the following circumstances is not covered by this warranty.
 - ◆ Mechanical, chemical or other damage sustained during or after installation.
NOTE: Clean swarf off shed **IMMEDIATELY** after assembly
Do **NOT** mark cladding with pencil
Do **NOT** allow manures, chemicals or other corrosive materials to have direct contact with cladding
Chemical damage will result if these instructions are not carried out
 - ◆ Force majeure or other causes beyond the control of Riverlea Group Ltd.
2. This warranty does not cover material installed in severe and very severe environmental situations, or in any area where the mild steel corrosion rate (as published by BRANZ) exceeds 200g/m².
3. Minimum maintenance must be carried out in accordance with instructions below.

Should the cladding fail to perform as specified above, the liability of Riverlea Group Ltd shall in all cases be limited to replacing or repairing the defective product. The balance of the original warranty will cover any repaired or replaced material. Riverlea Group Ltd will not be liable for any consequential loss or damage, labour or transport charges. All claims made in writing within 21 days of discovery, quoting the reference number at the top right hand corner of this page.

MAINTENANCE

Following are the minimum maintenance requirements for cladding used in Kiwi Garden Sheds and Fortress Sheds.

- ◆ Washing all surfaces by rain, and annual hosing of sheltered areas using a hose and soft nylon brush.
- ◆ Within 2km of coast—wash every 3 months as above. After a storm, wash the cladding and the gutters as soon as possible to remove any highly corrosive salt deposits.
- ◆ Volcanic Ash Fallout—wash as soon as possible, removing fallout from roof and gutters
- ◆ Gutters to be kept clean of leaves and dirt.

Should you require additional technical information please contact us at the details below.

WARRANTY REGISTRATION

Please visit <http://www.riverleagroup.co.nz/warranty-garden-sheds> to validate the Warranty on your shed.

Click on the Warranty Registration Link and complete all details.

If you are unable to access the computer, please phone us on 0800 438 274 and one of the customer services team will help you to activate the warranty on your garden shed.

Many thanks, from the Team at Riverlea Group.



PRODUCER STATEMENT – PS1 – DESIGN

(Guidance notes on the use of this form are printed on page 2)

ISSUED BY: **McDowall Structures**
(Design Firm)

TO: **Riverlea Group Ltd**
(Owner/Developer)

TO BE SUPPLIED TO: **Local Territorial Authority**
(Building Consent Authority)

IN RESPECT OF: **Standard Garden Sheds, Kiwi Garden Sheds MK3B MK4C & MK4B, for a 25 year design life, Importance Level 1**
(Description of Building Work)

AT: **A. Wind Zones: Up to and including, Very High (VH) Wind Zone, as per NZS3604:2011, Table 5.4**
B. Snow Zones: Sub-alpine regions of NZ as per NZS1170.3:2003, i.e., North Island below 1200m altitude, and South Island below 900m altitude
C. Seismic Zones: As per NZS1170.5:2004, Any Seismic Zone
 (Address)

..... LOT..... DP SO

We have been engaged by the owner/developer referred to above to provide Structural Engineering Design services in respect of the requirements of
(Extent of Engagement)

Clause(s) B1 of the Building Code for All or Part only X (as specified in the attachment to this statement), of the proposed building work.

The design carried out by us has been prepared in accordance with:

- Compliance Documents issued by the Ministry of Business, Innovation & Employment B1/VM1 or (verification method / acceptable solution)
- Alternative solution as per the attached schedule.....

The proposed building work covered by this producer statement is described on the drawings titled "Kiwi Garden Sheds, Construction Details" dated 20th August 2018, for the three types of garden shed referred to above.

and numbered A-01, A-02 & A-03 ; together with the specification, and other documents set out in the schedule attached to this statement.

On behalf of the Design Firm, and subject to:

- (i) Site verification of the following design assumptions Constructed on 'good ground' as per NZS 3804 and as confirmed on site by the owner's representative
- (ii) All proprietary products meeting their performance specification requirements;

I believe on reasonable grounds that a) the building, if constructed in accordance with the drawings, specifications, and other documents provided or listed in the attached schedule, will comply with the relevant provisions of the Building Code and that b), the persons who have undertaken the design have the necessary competency to do so. I also recommend the following level of construction monitoring/observation:

CM1 CM2 CM3 CM4 CM5 (Engineering Categories) or X, as per Council requirements as per agreement with owner/developer (Architectural)

I, **Bruce J McDowall** am: **X CPEng 55172 #**
 (Name of Design Professional) Reg Arch #

I am a Member of: IPENZ NZIA and hold the following qualifications: B.E., M.A.Sc., CPEng. The Design Firm issuing this statement holds a current policy of Professional Indemnity Insurance no less than \$200,000*. The Design Firm is a member of ACENZ:

SIGNED BY **B. J. McDowall**
 ON BEHALF OF **McDowall Structures**
 (Design Firm)



Date 27th August 2018 (signature)

Note: This statement shall only be relied upon by the Building Consent Authority named above. Liability under this statement accrues to the Design Firm only. The total maximum amount of damages payable arising from this statement and all other statements provided to the Building Consent Authority in relation to this building work, whether in contract, tort or otherwise (including negligence), is limited to the sum of \$200,000.

This form is to accompany **Form 2 of the Building (Forms) Regulations 2004** for the application of a Building Consent.

THIS FORM AND ITS CONDITIONS ARE COPYRIGHT TO ACENZ, IPENZ AND NZIA